



Jubiläums-Set 30 Jahre
Anniversary set 30 years



TRIAG

INTERNATIONAL

5AX-Master powerCLAMP

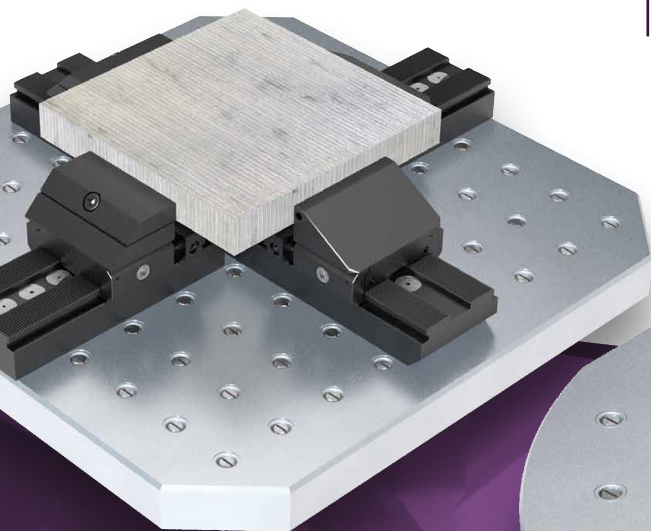

30 Jahre
Years

- ✓ Geeignet für 5-Achs-Anwendungen - Tischdimension ab \varnothing 500 mm
Ideal for 5-axis applications - table dimensions from \varnothing 500 mm
- ✓ Gute Zugänglichkeit bei kleinen sowie grossen Werkstücken
Good accessibility for small and large workpieces
- ✓ Schnelles Umrüsten mit zuverlässiger Wiederholgenauigkeit
Quick changeover with reliable repeat accuracy

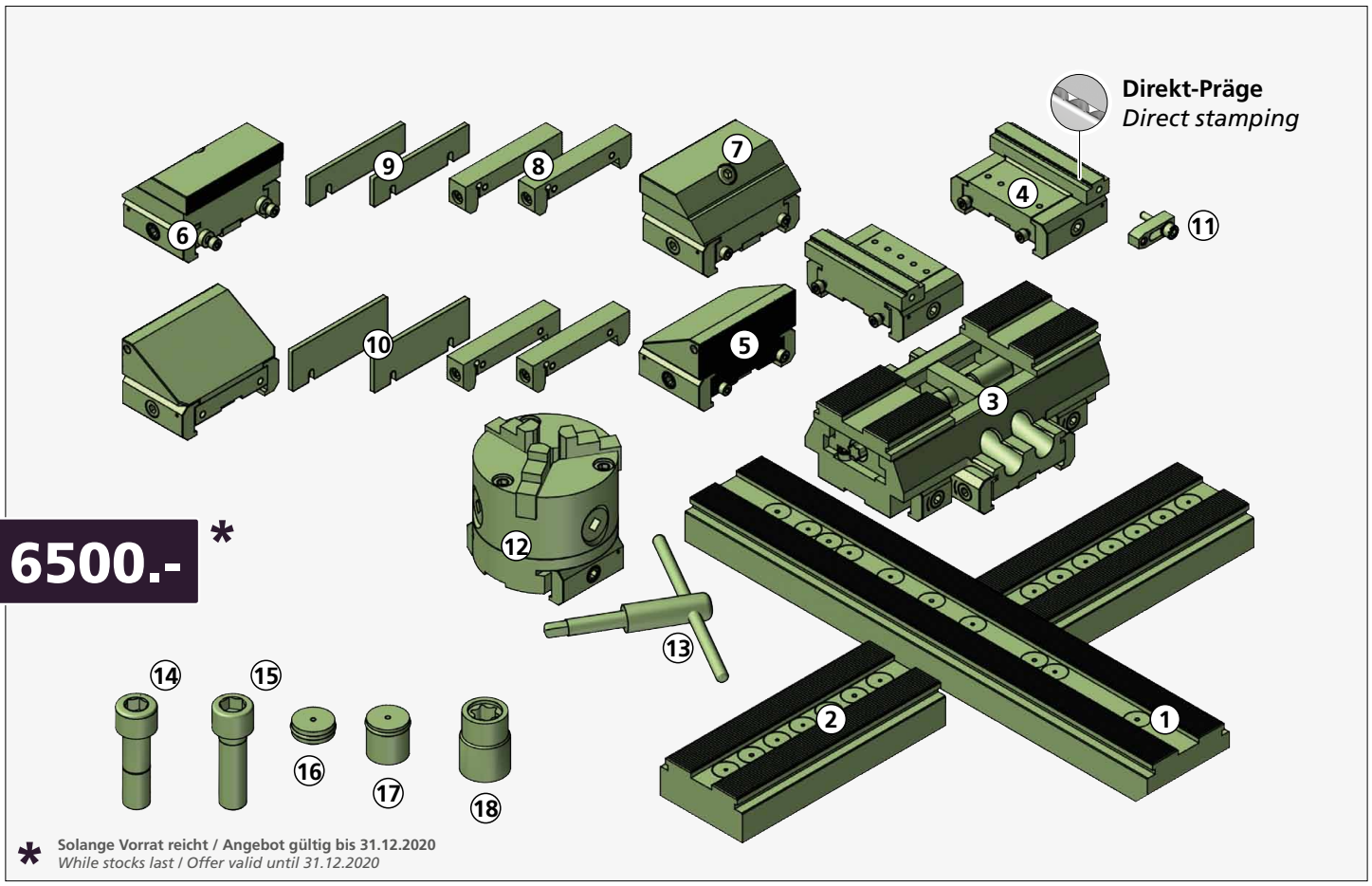

Artikel Nr. und Inhalt Article Nr. and content	Bezeichnung Description	~Kg
5AX500-30Y	Jubiläums-Set / Anniversary-Set	39,8
① 1x PCB4050450	Basisschiene / Base-rail 450 mm	8,9
② 2x PCB25200	Basisschiene / Base-rail 200 mm	7,2
③ 1x ZSM170L65GH200PCB	Zentrischspanner 90° drehbar / Self centering vise 90° turntable	8,6
④ 2x PAND94-34PRF-A1	Anschlagmodul mit Direkt-Prägebacke / End-module with direct stamping jaw 94 x 34	2,4
⑤ 2x PA5X94-49R	5-Achs Anschlagmodul, geriffelt / 5-axis end-module, double serrated 94 x 49	3,4
⑥ 2x PS5X94L49-105	5-Achs Spannmodul, linear / 5-axis clamping module, linear 94 x 49	3,0
⑦ 2x B111P	Backe geriffelt und pendelnd / Jaw with swiveling double serrated jaw 49 mm	0,5
⑧ 4x PCUH2594	Unterlagen- und Fräsanlaghalter / Holder for parallels and workpiece stop	0,8
⑨ 4x PCU24093	Parallelunterlage / Steel parallels	0,3
⑩ 4x PCU34093	Parallelunterlage / Steel parallels	0,4
⑪ 1x FA1240	Fräsanschlag / Milling buffer	-
⑫ 1x PS3X100L82BSET	Dreibackenfutter / Three jaw chuck Ø 100 mm	4,3
⑬ 1x 243864.0100000	Spannschlüssel / Clamping key	-
⑭ 6x TWPAS1240	Passschraube / Fitting screw Ø 12 f6 M12	-
⑮ 3x M12 x 40 ISO4762	Zylinderschraube / Cap screw	-
⑯ 9x PCPF16L6	Schutzkappe / Shut plug 6 mm länge / length	-
⑰ 15x PCPF16L18	Schutzkappe / Shut plug 18 mm länge / length	-
⑱ 1x NUSS3/8"TX30E14	Steckschlüsseleinsatz / Socket wrench insert	-
RPQ50504-R50	Rasterplatte / Grid plate 500 x 500 x 40	74
RPD504-R50	Rasterplatte rund / Grid plate round Ø 500 x 40	64

powerCLAMP

Eigenschaften
Features

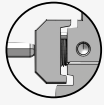

3D
MODULAR



Kreuzanordnung auf Rundtisch
Cross formation on round table

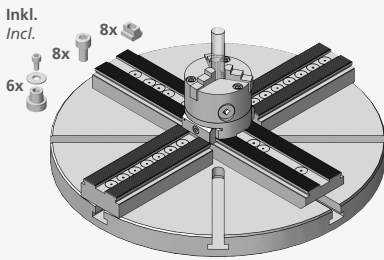

Beispiel 1 auf 5-Achs Maschinentisch
Example 1 on 5-axis machine table

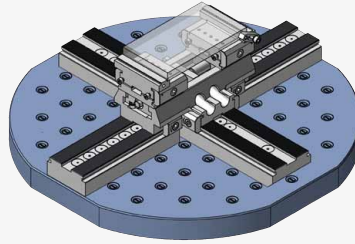

Beispiel 2 auf Rasterplatte rund Ø500 x 40
Example 2 on grid plate round Ø500 x 40

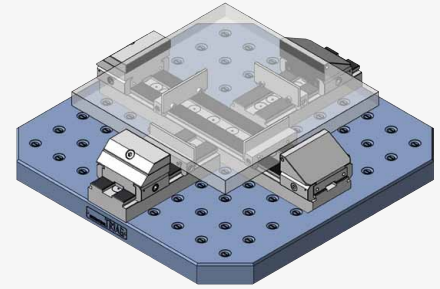

Beispiel 3 auf Rasterplatte 500x500x40
Example 3 on grid plate 500x500x40

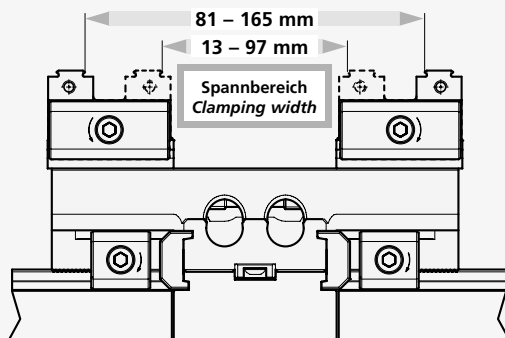
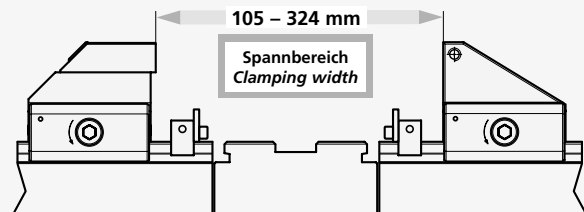
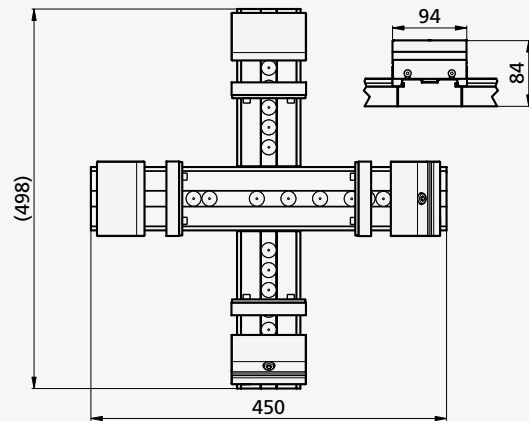
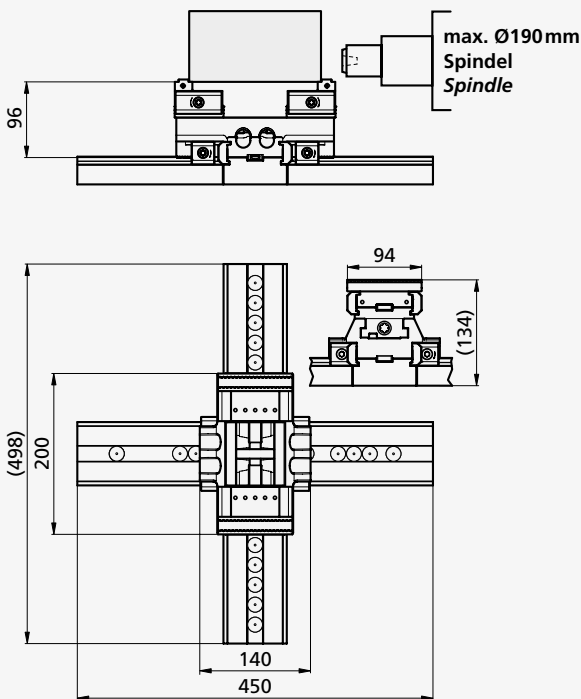

GESCHENK

Jubiläums-Grappa zu jedem Set

PRESENT

Anniversary Grappa to each set



30 Jahre
Years

Gute Zugänglichkeit - Unerlässlich bei 5-Achs Anwendungen.
Good accessibility - indispensable for 5-axis applications.

#triagint



Triag International AG



Triag International AG



Triag International



triagint_workholding

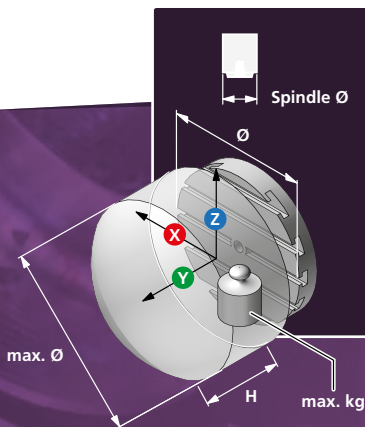
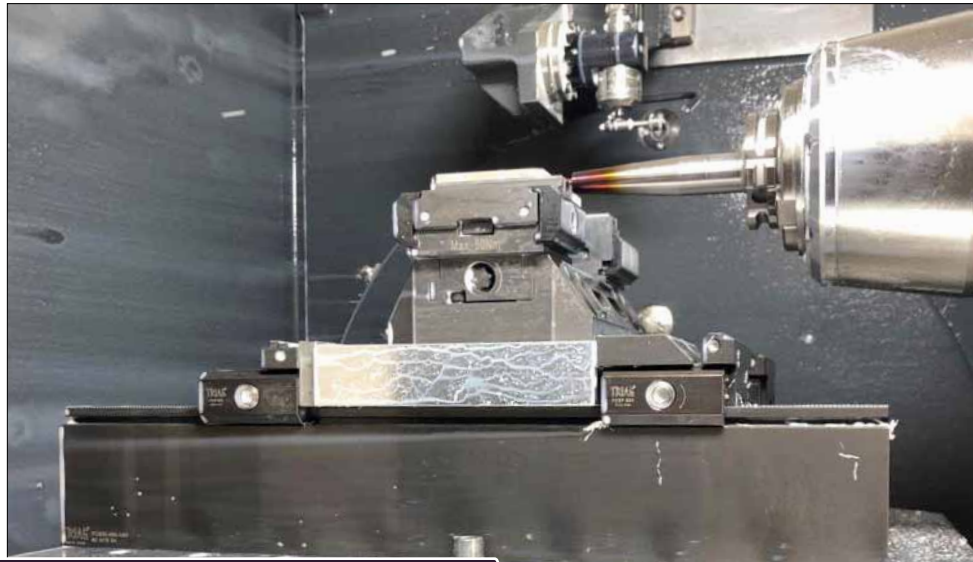

Bitte senden Sie uns Ihre Maschinendaten zu und überprüfen Sie den Spindeldurchmesser.

Please send your machine data and check your spindle diameter.

X- / X+
Y- / Y+
Z- / Z+

Triag International AG

Bösch 84 CH-6331 Hünenberg

+41 41 727 27 77

spannen@triag-int.ch

clamping@triag-int.ch

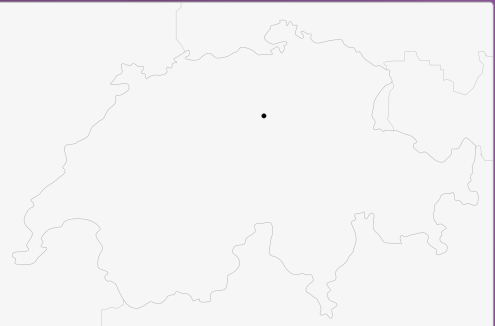

Mass- und Konstruktionsänderungen bleiben uns vorbehalten. We reserve the right to modify dimensions and structural design.

triag-int.ch

Official Website



05
20